

Dreamoc™

XL



A Cool New 3D Display that gives your product the competitive edge

The Dreamoc XL was designed to display products that could not fit into the standard size Dreamoc, like shoe brands as shown in the picture.

In today's highly competitive retail market top end brands and exclusive stores need exciting new ways to differentiate themselves from the competition.

The Dreamoc, from RealFiction, is a unique 3D display unit that conveys compelling product messages that consumers just can't ignore.

Dreamoc provides a dazzling combination of holographic-like, free-floating video images, with a display of the physical product. The video can be fully customised to fit your branding and colour.

Make your product stand out from the crowd with the powerful and eye-catching Dreamoc display.

Features:

- Visually stunning product display
- Generates positive attention
- Combines free-floating 3D elements and physical products
- Superior exposure and branding
- High reliability and long lifetime
- High brightness LED for product exposure

limited perceptions unlimited perceptions unlimited perceptions unlimited perceptions

PHONE: +27 11 880 2800 FAX: 27 11 880 2554
PHYSICAL: BUILDING B, 1 SAXON ROAD
HYDE PARK, JOHANNESBURG
PO BOX 3079, RANDBURG, 2125
SOUTH AFRICA

imajinn 
innovate

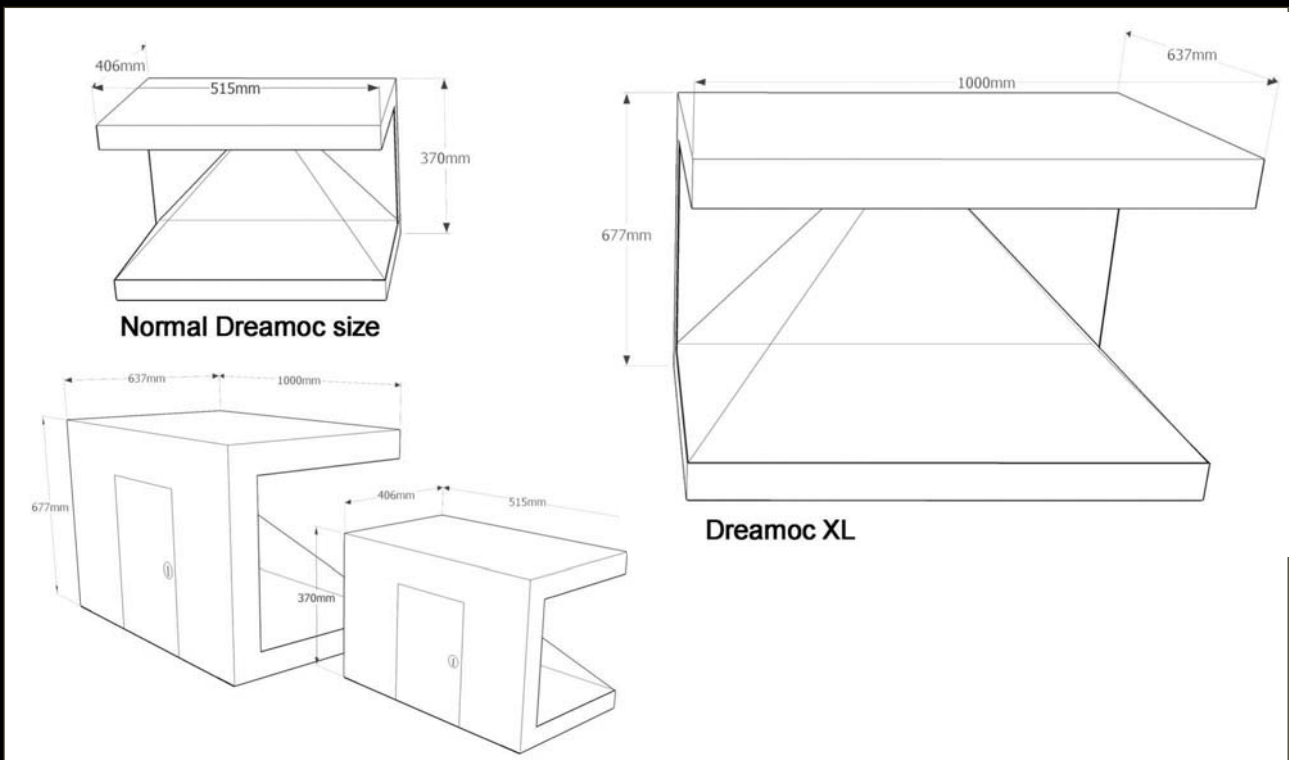

Unit comes without stand. This stand is only a demo.

Size without stand: H: 677 mm. W: 1000mm D: 637 mm

imited perceptions unlimited perceptions unlimited perceptions unlimited percep

PHONE: +27 11 880 2800 FAX: 27 11 880 2554
 PHYSICAL: BUILDING B, 1 SAXON ROAD
 HYDE PARK, JOHANNESBURG
 PO BOX 3079, RANDBURG, 2125
 SOUTH AFRICA